



# DESIGNERSTELLUNG RICHTLINIEN

# Druckvorlagen Erstellung

---

## Datei:

- Format 1:1
- Ohne zusätzlichen Beschnitt
- Maximale Größe 200 cm x Drucklänge (Toleranz +- 2%)
- Druckdatei: EPS, Ai oder PDF (mit RGB-Farbraum)
- Vorzugsweise: Ai (Adobe Illustrator)

## Farbauswahl:

- RGB-Farbmodus
- Farbprofil Adobe RGB 1998
- Farbprofil in der Datei einbetten
- Auflösung: 100dpi (Native-Modus)
- Schrift und Logos in Vektoren gewandelt
- Keine Bilder, keine Verläufe, bitte alles in Vektoren

## Farben / Texte:

- Farbpalette der Produktionsfarben anbei
- Farbe aussuchen – die Vektor Fläche RGB Werte eintragen  
– siehe Folgeseiten
- Mindestgrößen Striche und Schriften berücksichtigen  
– siehe Folgeseiten

## Wichtige Info: Vor dem speichern Schriften in Vektoren wandeln

Bitte pro Teppich/Matte immer nur 1 Datei einzeln.  
Nicht mehrere Daten in Sammel-PDF.

## Daten-Übermittlung:

Per Email [garcia@photofabrics.de](mailto:garcia@photofabrics.de) oder WeTransfer.

**Bitte schreiben Sie uns IN DER MAIL ZUSÄTZLICH, wenn Sie uns die Daten senden, welche Farben sie verwendet haben.**

Wir erstellen Ihnen dann ein Druckfreigabe PDF.

# Minimale Textgrößen

## Farbige Buchstaben

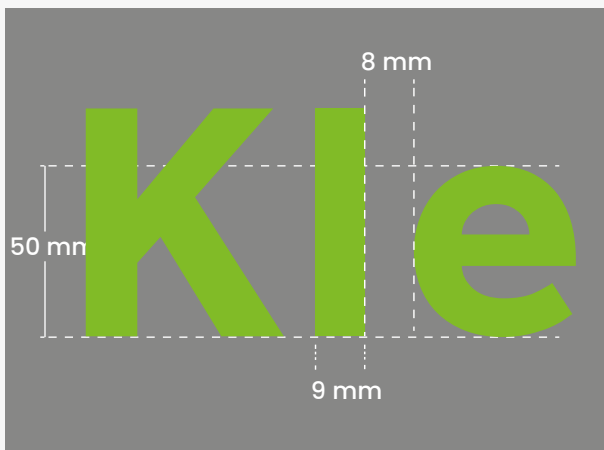

Serifenlose Schriftarten

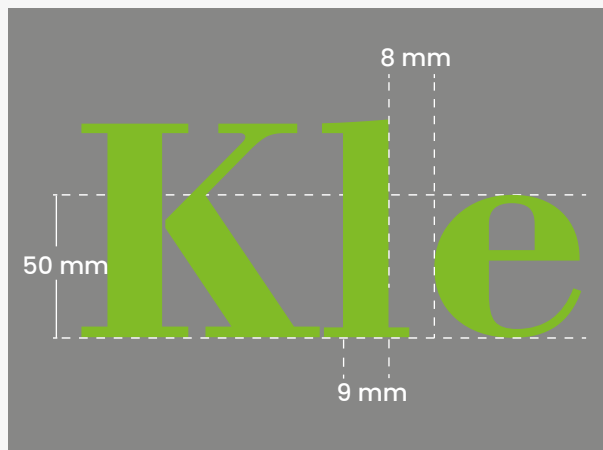

Schreibschriften und Schriftarten mit Serifen

## Weißer Buchstaben auf dunklem Hintergrund

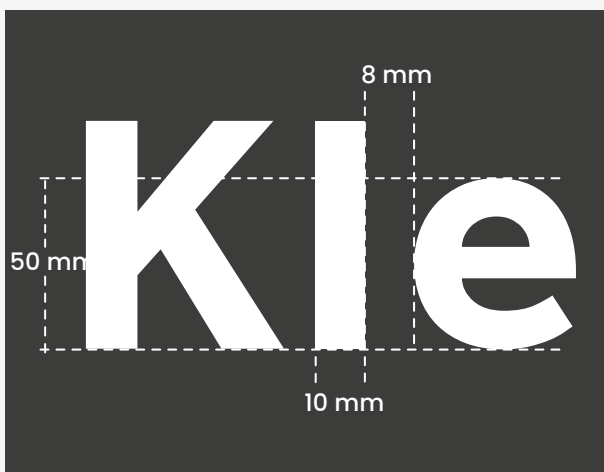

Serifenlose Schriftarten

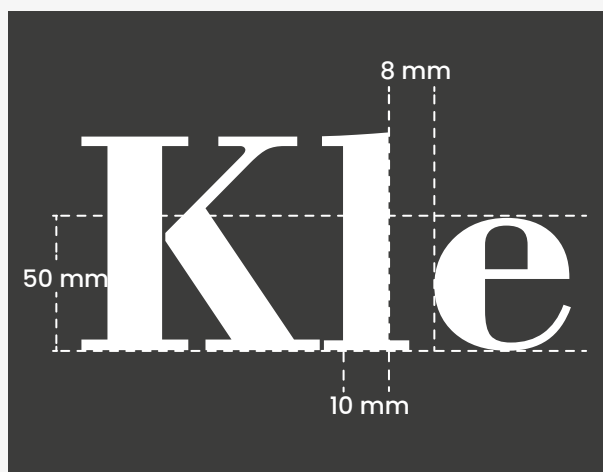

Schreibschriften und Schriftarten mit Serifen

# Minimale Strichstärken

## Helle Hintergrundfarben

Alle Strichstärken müssen mindestens 9 mm betragen.

9 mm

## Dunkle Hintergrundfarben

Alle Strichstärken müssen mindestens 10 mm betragen.

10 mm

# Farbkontrast

## Blau- und Grautöne

	629	630	631	632	654	665	666
613	Guter Kontrast	Guter Kontrast	Geringer Kontrast	Geringer Kontrast	Guter Kontrast	Guter Kontrast	Guter Kontrast
614	Geringer Kontrast	Geringer Kontrast	Guter Kontrast	Guter Kontrast	Geringer Kontrast	Geringer Kontrast	Geringer Kontrast
615	Guter Kontrast	Geringer Kontrast	Geringer Kontrast	Guter Kontrast	Geringer Kontrast	Guter Kontrast	Geringer Kontrast
624	Geringer Kontrast	Geringer Kontrast	Guter Kontrast	Guter Kontrast	Geringer Kontrast	Geringer Kontrast	Geringer Kontrast
637	Guter Kontrast	Geringer Kontrast	Geringer Kontrast	Guter Kontrast	Geringer Kontrast	Guter Kontrast	Geringer Kontrast



## Grün- und Grautöne

	629	630	631	632	654	665	666
617	Guter Kontrast	Geringer Kontrast	Geringer Kontrast	Geringer Kontrast	Geringer Kontrast	Guter Kontrast	Guter Kontrast
618	Geringer Kontrast	Guter Kontrast	Guter Kontrast	Guter Kontrast	Guter Kontrast	Geringer Kontrast	Geringer Kontrast
619	Guter Kontrast	Geringer Kontrast	Geringer Kontrast	Geringer Kontrast	Geringer Kontrast	Guter Kontrast	Guter Kontrast
620	Guter Kontrast	Geringer Kontrast	Geringer Kontrast	Guter Kontrast	Geringer Kontrast	Guter Kontrast	Geringer Kontrast
640	Guter Kontrast	Geringer Kontrast	Geringer Kontrast	Geringer Kontrast	Geringer Kontrast	Guter Kontrast	Guter Kontrast
621	Guter Kontrast	Geringer Kontrast	Geringer Kontrast	Guter Kontrast	Geringer Kontrast	Guter Kontrast	Geringer Kontrast



## Kombinationen aus ähnlichen Farben wie zB.:

	602	603	642	646	650	660	664
601	Geringer Kontrast	Geringer Kontrast	Geringer Kontrast	Geringer Kontrast	Geringer Kontrast	Geringer Kontrast	Geringer Kontrast

	604	606	607	639	645	652	661
605	Geringer Kontrast	Geringer Kontrast	Geringer Kontrast	Geringer Kontrast	Geringer Kontrast	Geringer Kontrast	Geringer Kontrast

	615	617	619	637	640	641	655
620	Geringer Kontrast	Geringer Kontrast	Geringer Kontrast	Geringer Kontrast	Geringer Kontrast	Geringer Kontrast	Geringer Kontrast

## Bitte beachten:

- Prüfen Sie Ihre gewünschten Kontraste vor Bestellung immer anhand unserer Originalfarbmuster.

# Punkte, die man beachten sollte

## Bitte...

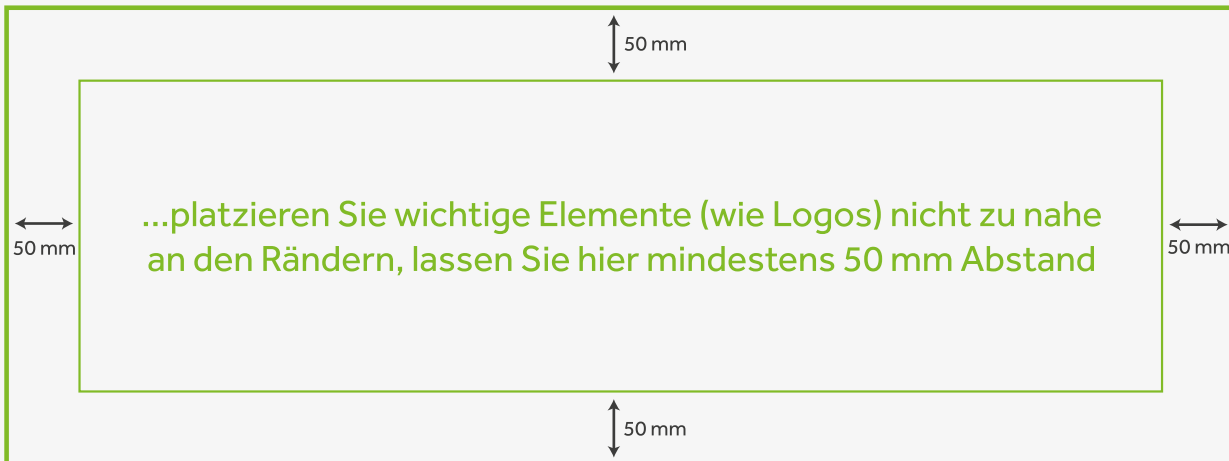

## Bitte verwenden Sie keine...



## Vorlagen mit Wasserzeichen Komplexe Muster

Eine Designerstellung aus Vorlagen mit Wasserzeichen ist uns nicht möglich. Dies führt zu einer Ablehnung des Designs.



**Farbkombinationen mit wenig Kontrast**

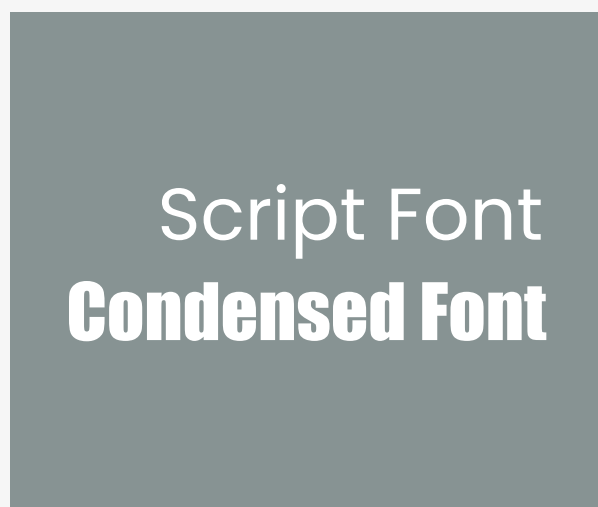

**Schreibschriften oder komprimierte Schriftarten**



# Standard-Farben PMS/RGB-Werte

 601 PMS 102 C RGB: 252 227 0	 602 PMS 7548 C RGB: 255 198 0	 603 PMS 1375 C RGB: 255 158 27	 604 PMS Orange 021 C RGB: 254 80 0	 605 PMS 200 C RGB: 186 12 47	 606 PMS 7622 C RGB: 147 40 44
 607 PMS 221 C RGB: 145 0 72	 608 PMS 211 C RGB: 245 126 182	 609 PMS 520 C RGB: 100 47 108	 610 PMS 2572 C RGB: 201 139 219	 611 PMS Violett C RGB: 102 0 161	 612 PMS 272 C RGB: 145 120 209
 613 PMS 286 C RGB: 0 50 160	 614 PMS 279 C RGB: 65 143 222	 615 PMS 641 C RGB: 0 120 173	 616 PMS 638 C RGB: 0 175 215	 617 PMS 329 C RGB: 0 104 94	 618 PMS 7472 C RGB: 92 184 178
 619 PMS 3537 C RGB: 0 75 30	 620 PMS 347 C RGB: 0 154 68	 621 PMS 5185 C RGB: 71 38 56	 622 PMS 5215 C RGB: 175 149 166	 623 PMS 2767 C RGB: 19 41 75	 624 PMS 646 C RGB: 94 138 180
 625 PMS 7594 C RGB: 124 58 45	 626 PMS 487 C RGB: 234 167 148	 627 PMS 440 C RGB: 56 46 44	 628 PMS 434 C RGB: 208 196 197	 629 PMS 422 C RGB: 158 162 162	 630 PMS 431 C RGB: 91 103 112
 631 PMS 432 C RGB: 51 63 72	 632 PMS Process Black C RGB: 0 0 3	 633 PMS 7527 C RGB: 214 210 196	 634 PMS 4252 C RGB: 182 162 132	 635 PMS 2344 C RGB: 249 126 108	 636 PMS 2189 C RGB: 0 51 73
 637 PMS 3015 C RGB: 0 98 155	 638 PMS 504 C RGB: 79 31 38	 639 PMS 201 C RGB: 157 34 53	 640 PMS 349 C RGB: 4 106 56	 641 PMS 7761 C RGB: 125 120 40	 642 PMS 580 C RGB: 212 222 181
 643 PMS 1395 C RGB: 153 96 23	 644 PMS 7531 C RGB: 122 104 85	 645 PMS 215 C RGB: 172 20 90	 646 PMS 2291 C RGB: 167 213 0	 647 PMS 3125 C RGB: 0 174 199	 648 PMS 7415 C RGB: 230 186 168
 649 PMS 258 C RGB: 140 71 153	 650 PMS 131 C RGB: 199 148 13	 651 PMS 2766 C RGB: 20 27 77	 652 PMS 1925 C RGB: 224 0 77	 653 PMS 1405 C RGB: 110 76 30	 654 PMS Cool Grey 10 C RGB: 99 102 106
 655 PMS 361 C RGB: 67 176 42	 656 PMS 476 C RGB: 78 54 41	 657 PMS 289 C RGB: 12 35 64	 658 PMS 7666 C RGB: 92 78 99	 659 PMS 666 C RGB: 161 146 178	 660 PMS 465 C RGB: 212 180 102
 661 PMS 1525 C RGB: 185 71 0	 662 PMS 548 C RGB: 0 61 76	 663 PMS 7515 U RGB: 153 112 89	 664 PMS 7486 C RGB: 188 225 148	 665 PMS 428 C RGB: 193 198 200	 666 PMS 430 C RGB: 124 135 142

# PC-Farben

rgb: 237 110 0

<b>PMS 102C</b> rgb: 252 227 0 <b>601</b>	<b>PMS 7548C</b> rgb: 255 198 0 <b>602</b>	<b>PMS 1375C</b> rgb: 255 158 27 <b>603</b>	<b>PMS Orange 021C</b> rgb: 254 80 0 <b>604</b>	<b>PMS 200C</b> rgb: 186 12 47 <b>605</b>
<b>PMS 7622C</b> rgb: 147 40 44 <b>606</b>	<b>PMS 221C</b> rgb: 145 0 72 <b>607</b>	<b>PMS 211C</b> rgb: 245 126 182 <b>608</b>	<b>PMS 520C</b> rgb: 100 47 108 <b>609</b>	<b>PMS 2572C</b> rgb: 201 139 219 <b>610</b>
<b>PMS Violett C</b> rgb: 102 0 161 <b>611</b>	<b>PMS 272C</b> rgb: 145 120 209 <b>612</b>	<b>PMS 286C</b> rgb: 0 50 160 <b>613</b>	<b>PMS 279C</b> rgb: 65 143 222 <b>614</b>	<b>PMS 641C</b> rgb: 0 120 173 <b>615</b>
<b>PMS 638C</b> rgb: 0 175 215 <b>616</b>	<b>PMS 329C</b> rgb: 0 104 94 <b>617</b>	<b>PMS 7472C</b> rgb: 92 184 178 <b>618</b>	<b>PMS 3537</b> rgb: 0 75 30 <b>619</b>	<b>PMS 347</b> rgb: 0 154 68 <b>620</b>
<b>PMS 5185C</b> rgb: 71 38 56 <b>621</b>	<b>PMS 5215C</b> rgb: 175 149 166 <b>622</b>	<b>PMS 2767</b> rgb: 19 41 75 <b>623</b>	<b>PMS 646C</b> rgb: 94 138 180 <b>624</b>	<b>PMS 7594C</b> rgb: 124 58 45 <b>625</b>
<b>PMS 487C</b> rgb: 234 167 148 <b>626</b>	<b>PMS 440C</b> rgb: 56 46 44 <b>627</b>	<b>PMS 434C</b> rgb: 208 196 197 <b>628</b>	<b>PMS 422C</b> rgb: 158 162 162 <b>629</b>	<b>PMS 431C</b> rgb: 91 103 112 <b>630</b>
<b>PMS 432C</b> rgb: 51 63 72 <b>631</b>	<b>PMS Process Black C</b> rgb: 0 0 3 <b>632</b>	<b>PMS 7527C</b> rgb: 214 210 196 <b>633</b>	<b>PMS 4252C</b> rgb: 182 162 132 <b>634</b>	<b>PMS 2344C</b> rgb: 249 126 108 <b>635</b>
<b>PMS 2189C</b> rgb: 0 51 73 <b>636</b>	<b>PMS 3015C</b> rgb: 0 98 155 <b>637</b>	<b>PMS 504C</b> rgb: 79 31 38 <b>638</b>	<b>PMS 201C</b> rgb: 157 34 53 <b>639</b>	<b>PMS 349C</b> rgb: 4 106 56 <b>640</b>
<b>PMS 7761C</b> rgb: 125 120 40 <b>641</b>	<b>PMS 580C</b> rgb: 212 222 181 <b>642</b>	<b>PMS 1395C</b> rgb: 153 96 23 <b>643</b>	<b>PMS 7531C</b> rgb: 122 104 85 <b>644</b>	

# PC-Farben

<b>PMS 215C</b> rgb: 172 20 90 <b>645</b>	<b>PMS 2291C</b> rgb: 167 213 0 <b>646</b>	<b>PMS 3125C</b> rgb: 0 174 199 <b>647</b>	<b>PMS 7415C</b> rgb: 230 186 168 <b>648</b>	<b>PMS 258C</b> rgb: 140 71 153 <b>649</b>
<b>PMS 131C</b> rgb: 199 148 13 <b>650</b>	<b>PMS 2766C</b> rgb: 20 27 77 <b>651</b>	<b>PMS 1925C</b> rgb: 224 0 77 <b>652</b>	<b>PMS 1405C</b> rgb: 110 76 30 <b>653</b>	<b>COOL GREY 10 C</b> rgb: 99 102 106 <b>654</b>
<b>PMS 361C</b> rgb: 67 176 42 <b>655</b>	<b>PMS 476C</b> rgb: 78 54 41 <b>656</b>	<b>PMS 289C</b> rgb: 12 35 64 <b>657</b>	<b>PMS 7666C</b> rgb: 92 78 99 <b>658</b>	<b>PMS 666C</b> rgb: 161 146 178 <b>659</b>
<b>PMS 465C</b> rgb: 212 180 102 <b>660</b>	<b>PMS 1525C</b> rgb: 185 71 0 <b>661</b>	<b>PMS 548C</b> rgb: 0 61 76 <b>662</b>	<b>PMS 7515U</b> rgb: 153 112 89 <b>663</b>	<b>PMS 7486C</b> rgb: 188 225 148 <b>664</b>
<b>PMS 428C</b> rgb: 193 198 200 <b>665</b>	<b>PMS 430C</b> rgb: 124 135 142 <b>666</b>			



# Kontaktdaten

---

Rafael Garcia

[garcia@photofabrics.de](mailto:garcia@photofabrics.de)

Tel. direkt +4971412984534

PhotoFabrics GmbH

Teinacherstraße 40

71634 Ludwigsburg

Deutschland

[www.teppich-printer.de](http://www.teppich-printer.de)

[www.photofabrics.de](http://www.photofabrics.de)

Farbabweichungen können auftreten | Bitte beachten Sie, dass wir auf Kunstfaser-Oberflächen und nicht auf glattem Papier drucken